

Development of a Knowledge-Rich CAD System for the North American Precast Concrete Industry

Charles Eastman, Ghang Lee

Design Computing, Georgia Institute of Technology

Rafael Sacks

Civil and Env. Eng., Technion – Israel Institute of Technology

Abstract

The downstream production sectors of the construction industry are developing powerful parametric modeling design and engineering tools for fabrication modeling. This paper reports an effort by the North American precast concrete industry toward developing such tools. Some implications for architectural design and practice are outlined.

1 Introduction

A significant revolution is taking place in the production of buildings. After years ignoring the development of digital modeling methods in manufacturing and electronics, the construction industry is beginning to adopt these methods. Journals and AEC software firms have adopted the term “Building Information Model” (BIM) to refer to this new technology (Laizerin, 2003). BIM assumes that a fully detailed 3D model is the base representation for building projects, used by architect, contractor, sub-contractors and as required for design, production and erection. Drawings are semi-automatically produced as reports from the building model, as are bills of material and production plans, such as 4D simulation (Koo & Fischer, 2000). Subcontractors, such as those for steel structures, precast concrete and cast-in-place concrete, façade and curtainwall fabricators, would all use the Building Information Model for detailing and shop production, with the general contractor using the various BIM models to coordinate all specialties.

While it was originally expected that architects would lead this transition, they have not done so. A construction level 3D model, with fully attributed objects, involves more information than is currently provided in drawings. With tight, fixed fee structures, there is little incentive to provide more information for downstream users without additional compensation. Justification for additional compensation for 3D modeling has not been forthcoming.

More fundamentally, software tools to model contract-drawing-level definition of whole buildings, beyond the scale of a single-family residence, have not been readily available. Few systems have been able to support interactive modeling of more than a few thousand parts, while a medium sized building may have millions. While the potential of such capabilities has been promoted since the 1970s, the knowledge to realize them, the hardware technology, and the software, have not been widely available. The CAD literature is filled with firms formed by young innovators promoting these changes – Calma, GDS, Reflex, RUCAPS, Sonata, TriCad and more.

Part of the reason that this transition may occur (this time) is that other parts of the construction industry have already begun to make the transition. Structural steel is largely designed, analyzed, detailed, fabricated and erected using integrated 3D modeling systems, (using such programs as Xsteel, SDS/2, 3D+, StruCad and others). The precast concrete industry is currently developing similar capabilities. These sectors of the construction industry have recognized that 3D modeling is not a religious belief, but rather a practical business decision. Even starting with architect's drawings and building their own 3D models, they gain major benefits, including: faster design, detailing and production, improved support for automation and reduced errors due to internal coordination (Sacks et al, 2003b).

These activities involve technologies that architects may eventually utilize, or with which they will need to exchange data. Some of the technology challenges in these industry sectors resolve issues also encountered in architectural design. There have been concerns expressed that architects have become too separate from the methods of construction (Cooke, 2000). Yet active involvement in the development of IT in these other sectors of construction give architects a leading role in guiding and directing future practices in their industry. The technologies are leading to re-structuring of the construction industry, affecting the possible roles that architects may play.

The authors are the technical consultants to a non-profit consortium, called the Precast Concrete Software Consortium, which consisted of 23 precast concrete producers. The purpose for forming this consortium was to develop a strong business plan for advancing IT application in the precast concrete industry of North America. The consortium shared in the cost of developing a plan for bringing advanced information technology capabilities to the precast concrete industry and then funded its realization. The authors prepared the business plan and are now coordinating its implementation. This paper gives a short review of the precast concrete industry, then reviews the project as undertaken, and lastly describes some of the implications of the project for architectural design and practice.

2 An Industry Led Consortium to Develop Advanced IT

While the Romans were the first to precast concrete, it was first introduced into North America in the 1920s, then became more widespread during the 1950's, with increased use of prestressing (PCI, 1999). It is a significant contributor in many building types,

including office buildings (whole buildings or facades), sports stadiums, and parking garages. The precast concrete industry's share of the construction market in general, is small in comparison with other industrialized regions (Sacks et al., 2003a), the total being 1.2%. The largest single market is that for parking deck structures, with \$1,010M, representing 13% of the market. In contrast, in Finland, 25% of all structural slabs and 11% of all building facades are precast (FCIA, 2000; RTT, 2001).

In contrast to wood and steel, few standard stock items of precast can be bought "off-the-shelf. Only hollow-core floor slabs are of this character. Tees, spandrels, beams and double tees are custom designed for span and loading, as are all wall panels. Most external panels have custom surface finishes. Connections must be custom designed for their conditions, including loading and appearance. In contrast to steel, a single precast concrete piece may involve a hundred or more individual component parts that must all be defined and fabricated. Almost all precast pieces are designed and engineered to-order and many of their component elements are also custom fabricated from library designs.

While most precast concrete companies operate as subcontractors to a general contractor in the traditional manner, several highly successful precast firms also provide design-build services. These provide complete services for the design and construction of largely precast structures, especially parking garages. A few also offer design-build services for office buildings.

A variety of production innovations are being explored by precast fabricators, including styrofoam molds for architectural faced panels that are easily produced from 3D models (Columbia, 2000), automated rebar and reinforcing, mesh bending and placement (Dunston & Bernhold, 1993), and automatic pouring and curing assembly lines.

The competitors of precast are cast-in-place reinforced concrete (CIP) and steel construction. Their relative shares of the market for building structures in 1997 were: CIP concrete: 69%, Structural Steel: 21%, and Precast: 10% (PCI, 2001; Economic Census, 2000; Economic Census 2001). (Some of these figures are difficult to compare; some deal with building construction, while the earlier ones deal with all construction.)

2.1 An IT Plan for Precast Concrete

This precast concrete IT project arose because of parallel activities in other competing industry sectors and on the recognition that future detail design and construction in the precast concrete industry could be greatly enhanced through automated 3D modeling.

While the precast industry had adopted several automation tools, for both engineering design and fabrication, almost all firms relied on 2D drafting software, such as AutoCAD and Microstation. Thus any automation tools had to rely on separate input and output translation. They also had the standard construction errors caused by inconsistencies between drawings (Sacks et al, 2003b). The consortium members also had extensive experience in developing custom software and add-ons, either internally by their firms, or through contracting with software firms. At least one firm had gone through three

generations of such efforts. These inevitably led to continuing maintenance costs and eventual obsolescence. They expressed desire for development of a commercial product by an established CAD company. They wanted a product that could support the whole precast concrete industry, in North America and possibly the world. They hired (the authors) to generate a white paper (8 week effort) for a plan for precast IT development (Eastman & Augenbroe, 2000).

The resulting plan included:

1. elicitation and compilation of detailed *process models* of how each firm contracts, designs, produces and erects precast concrete structures (whether as complete buildings, as facades or other components of an overall structure, or as individual pieces), to identify key business process, bottlenecks and cost items,
2. development of a *detailed specification* describing the functionality required for next generation parametric modeling CAD design and engineering software, to provide the design and engineering data to be used by all other processes,
3. *distribution of the specification* to potentially interested software companies, *evaluation of the alternative proposals* and *selection* of the software development team to work with,
4. *technical coordination to develop a detailed specification*, jointly developed by the consortium and the selected software company, with review and assessment of the software, as it becomes available,
5. *development of a building data model* to integrate the engineering and design functions of the specified software with other company software.

The process modeling exercise led to the recognition that traditional process modeling efforts were weakly effective, which in turn led to the development of a new process modeling method and process modeling tool. These efforts were directed at eliciting stronger input information for capturing information flows within a process, to support the development of improved tools and backend data model (Lee et al, 2003)

Step (2) included development of an 88 page specification that relied on the collected process modeling information. It described parametric 3D modeling technology that would allow significant re-engineering of precast concrete design, engineering and production. The software would have to support automated engineering, and semi-automated production of drawings. The specification and its implications are reviewed further in the next section. Step (3) involved discussions with 26 companies, with development proposals received from 13 business groups. Through multiple levels of review, these were reduced to 5, then 2, then the selection of the winner, Tekla Corporation, a large software firm from Finland that already has steel detailing applications. We are currently involved in steps (4 & 5), developing a detail specification and reviewing and assessing the software, as it reaches beta production. The consortium will begin study of the product model in the Fall of 2003.

This effort allowed the authors to review the current state of parametric CAD. It also allowed us to specify an advanced design and engineering CAD system that took full advantage of newly available parametric capabilities. The effort also required gaining thorough understanding of the engineering, design and production expertise that goes into a precast concrete product. For more detail, see (Sacks et al, 2003c)

3 Overall System Architecture Specification

The parametric CAD platform had to respond to a wide range of requirements. This included different businesses, where some precast fabricators contracted for, designed and produced whole buildings, while others produced a system, such as a floor structure or façade panels as a sub-contractor. The consortium included members from Canada and Mexico, as well as the USA; they rely on a variety of building and structural codes and standards. At the same time, many firms had special connections and piece designs they liked or were specialists at producing.

3.1 Process Model

The overall domain of functionality of the precast design software was derived from the different process models acquired from the precast companies. It is summarized in Figure One. The software had to support different starting points: (1) importing a 3D model from the architect and contractor, (2) acquiring digital drawings from the contractor or architect and constructing a 3D model from them, (3) building a 3D model of selected assemblies, when whole systems are not required, and design of individual pieces, when assemblies are not required. The process followed is top-down, with the overall building assembly being designed first, with detailing of the assembly to deal with connection locations, coordinated surface treatments and finish layouts, assembly level definition of reveals, bull noses, and other architectural shapes. The building assembly is also analyzed structurally to determine the loads and reactions applied to individual pieces.

The individual pieces are then detailed, within the context defined by the overall building. Each piece is designed in response to spatial and aesthetic issues, then engineered to behave correctly, given its loads and reactions. It has its connections defined according to the types and arrangements determined at the building assembly. The fabrication of each part is planned, in terms of its geometry, component parts, materials, embeds, finishes and so forth.

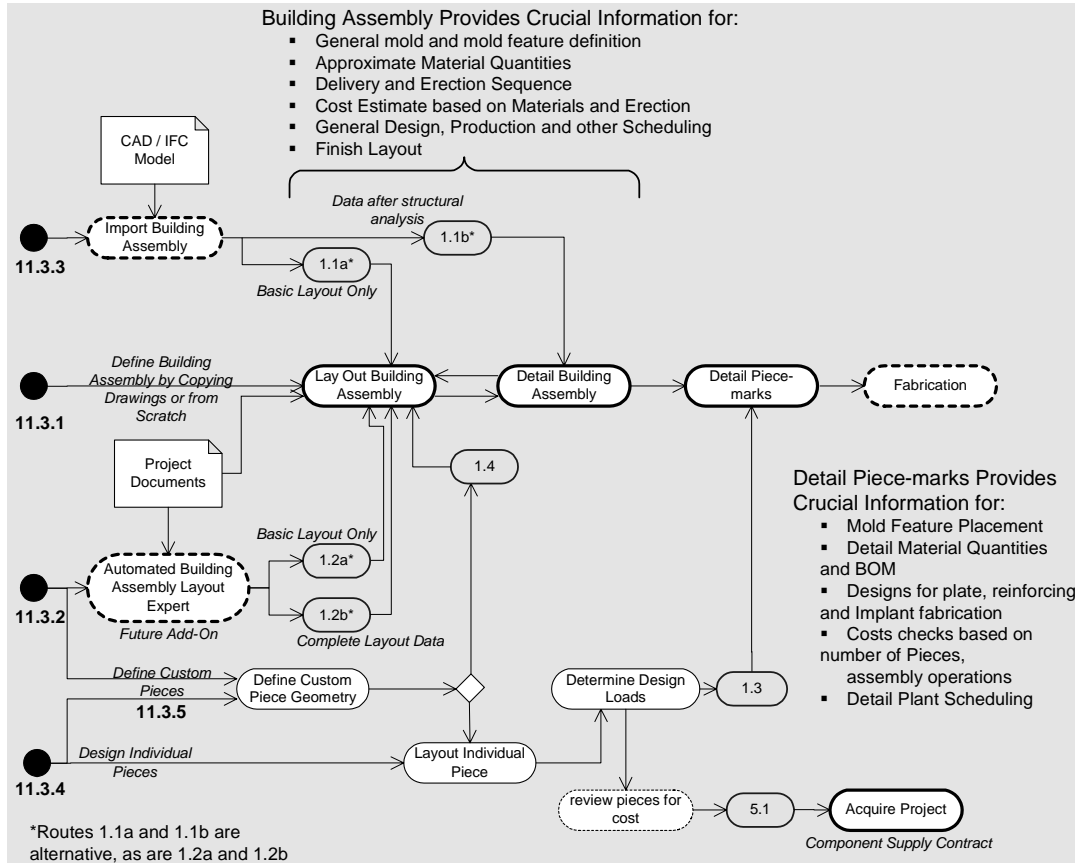

Figure One – A high-level process plan of the functional role of the precast concrete design and engineering application described in this article.

3.2 System Architecture

The widely varying functional and engineering capabilities that the precast concrete design and engineering package had to provide led to a somewhat elaborate system architecture, shown in Figure Two. This industry alone was not likely to be able to support its own geometric modeling platform, and there are a rich set of such platforms existing already. However, a general-purpose 3D parametric modeling system, such as Autodesk Inventor or Solidworks was not sufficient either. What was needed was the development of a *precast concrete platform*, consisting of effective interactive procedures to define any type of precast concrete piece, lay out any pattern of reinforcing and pre- or post-tensioning, layout and detailing of finishes and 3D architectural detailing, and definition of all embedded components for connections. In addition, to support parametric design, these components had to be defined generically, so they could take any form, but have automatic updating behavior, so that, for example:

- connections move and automatically redefine themselves as the pieces they connect are modified,

- floor layout systems update themselves when their boundaries change,
- or façade layouts update themselves when the panel partitions or fenestration patterns are modified.

These behaviors have been worked out carefully to work within the context of the Tekla software. In some cases, however, expansion of the parametric modeling platform capabilities was required and are included in the detailed specifications.

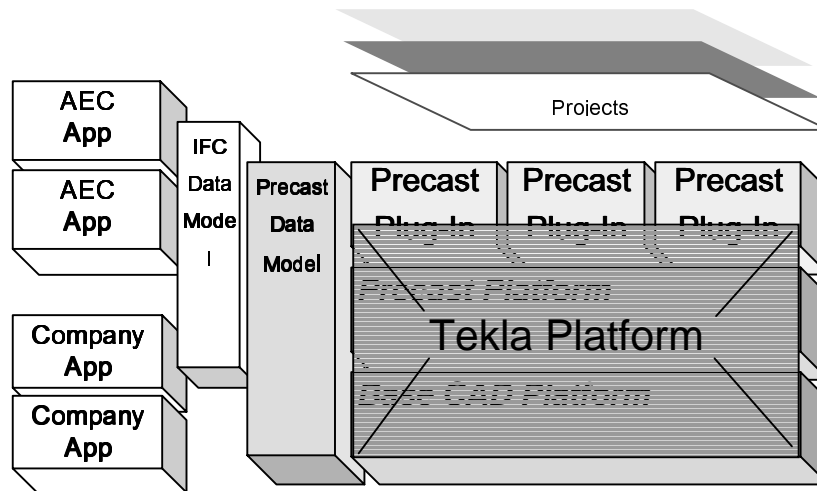

Figure Two – System architecture for the PCSC Precast Software; Tekla proposed a system that incorporates a base CAD platform, a precast platform, and several automated design and engineering functions.

Because of the wide range of building types, earthquake zones, company practices, it was recognized that a wide and open range of customization would be required. Plug-in development, using an open Application Programming Interface (API) was specified, incorporating Common Object Model (COM) and VBA (Visual Basic for Applications) scripting. Some of these applications, developed by third parties, have already been prototyped. The most immediate requirement is for automated engineering and layout of precast piece reinforcing, and the development of building system structural analysis. Other plug-in applications proposed include those for bridge girders and for automated design and detailing of parking garages.

Because the specified application would generate all the geometry and design data, it needs to interact with a range of other applications. These include (of course) coordination with 3D models of all the other systems. While for complex integration, it has been assumed that the precast model may also model some critical systems it interacts with (structure, electrical conduits), the main expected interface will be with the Industry Foundation Class (IFC) building exchange model, developed by the IAI (IAI, 2003). A Precast Concrete Building Model is planned. It will provide the IFC interface, those with general-purpose structural analysis applications, with CNC code generators (if

needed) and bill of materials, scheduling, material resource and Enterprise Resource Planning (ERP) systems.

In the competition resulting from the Request for Proposal for this system (Eastman et al., 2001), (in early 2002) twelve submitters proposed to develop systems based on this architecture. These included AutoCAD developers, who generated three proposals (that were eliminated because the AutoCAD platform lacked parametric modeling capabilities). Others included Bentley Triforma, Nemetschek Allplan, two Solidworks developers, Tekla, and Unigraphics from EDS-PLM. Benchmarks and technical development were assessed, as well as business practices and levels of expected support. The mixture of criteria for: strong parametric modeling, ability to interactively model at least 250,000 elements, easy extensibility and customization and an open architecture to support the whole industry, resulted in there being only a few companies that could contend. This situation has not changed much today, though we expect significant changes in the next two or so years. Finally, Tekla's Xengineer was selected, with significant additional required enhancement. Their product and proposal provided for the CAD platform, the Precast CAD platform, and some level of plug-in level automation, as an integrated package (as shown in Figure Two).

The detailed specification of the system, based on this architecture, is well along. Partial implementations are being continuously evaluated and some pilot testing on full buildings is scheduled for the summer of 2003. The full product release of the software, with all enhancements, is scheduled for October, 2004.

Many aspects of this effort offer insights into efforts that might be taken in other realms in construction, including architectural practice. Two aspects are reviewed in more detail below.

4 Automated Engineering

Buildings are complex structures that involve significant knowledge and decisions regarding layout and detailing, at every level of design, from schematic design to detailing. Automation is being applied to all levels of design and engineering of precast concrete.

4.1 Structural Stability

While precast structures must respond to a variety of requirements, including thermal and acoustic, the most universal functional requirement of precast structures is structural stability. Satisfying the structural requirements for precast involves two levels of design: at the building and at the piece level. At a high level, the building system must be analyzed according to the various loading requirements required by different regions of the country (or world). For low-rise buildings, most precast firms rely on formula-based analyses, based on the PCI Design code (PCI, 1999). For medium and high-rise construction, analysis is done using general-purpose finite element modeling systems.

The first capability will be supported through development of plug-in applications. General-purpose structural modeling systems are expected to be supported through the Precast Concrete Data Model, similar to the interfaces already provided by the CIMsteel model for structural steel (Crowley and Watson, 2000). Given the results of the analysis at this level, which usually requires multiple iterations, and making assumptions regarding piece-level design, a working solution is found. These results are then used to drive two more detailed designs: of the individual pieces, and of the connections between the pieces.

The piece level detailing involves automatic layout of the reinforcing and prestress cables of a given member shape, to satisfy the loads imposed by the overall structure. The plug-in applications will provide these services, based on the varied codes applied in different regions of North America. They define the longitudinal and cross-sectional reinforcing responding to the varied loading conditions throughout the length of the piece and must take into account the possibility of a changing profile along the piece's length, as well as holes and other irregularities within the piece.

In design, a connection is a logical entity, whose main role is to modify the two pieces being connected. Precast connections are highly varied, ranging from the ledge on an inverted tee, to pockets that might be used on a thick column, to corbels that protrude from a piece to carry another member. These may be selected interactively or assigned automatically, based on local conditions. In either case, their detailing will be driven by the loads they are determined to be carrying in the building level analysis. Because of the local loads on a connection, which will vary by type, they also carry local reinforcing.

There is not a clear dependency relation in the order in which piece reinforcing and connection detailing is to be undertaken. In some cases, it makes sense to do the connection design first, in others, the piece reinforcing. However, in the end, they must both work together, with no spatial conflicts, with some lapping of reinforcing, and other criteria. It has been specified that reinforcing and embed clash checking be included, and that this capability can be embedded in higher level checking routines.

This example of automated engineering design, with the limits of what can be automated and what cannot, shows both how great improvements are possible, and at the same time, there is still need for additional research for further improvements in the future.

4.2 Detailed Assembly Layout

The primary method of embedding engineering and construction practices into a design with CAD drafting technology is the copying and adjusting of detail sections. Typical sections are provided by window, curtainwall, door, fixture, exterior material and other material suppliers. However, these cut-and-paste operations often lead to inconsistencies with the actual context where they are specified or to details that are inappropriate for the condition they are applied to, leading to leaks, wear and poor installation and operation.

In the precast concrete software, every piece is defined with its spacing tolerances, with

cover requirements for concrete (for embeds), and its shape relationships with other pieces (such as a corbel connection on a column). See Figure Three. Thus the form of the detail is not stored, but rather the rules for generating the appropriate form in various conditions. As specifiers of the system, we play the game of asking how a piece should behave when changed in unusual ways. We try to cover them all. The proposed revisions are reviewed by a technical committee who together have hundreds of years of experience making such design decisions. The end result is that we will have embedded a significant portion of the design and engineering practices into this new system. Will it be infallible? No. But it will go a very long way in automating the everyday engineering and design practice of this industry. Will it prohibit unusual designs? That it does not has been a strong and continuing requirement. It must be possible to override every aspect of the design, so that users are not limited by the system. If a better way is found for a connection, or seam between pieces, then it should be easily automated, so that it can be used with the same efficiency as previously automated features.

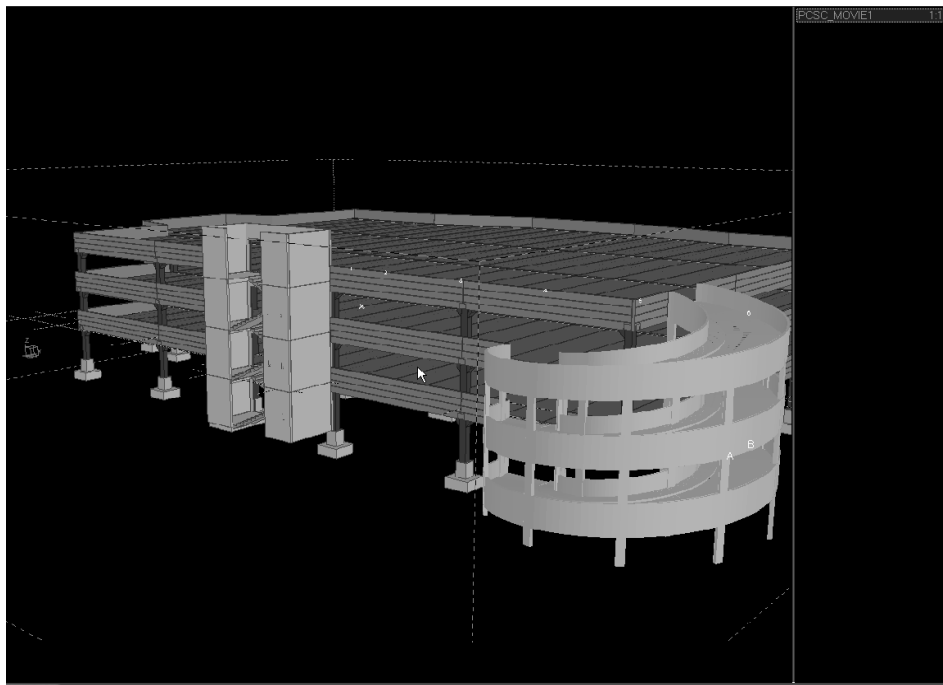

Figure Three: A Common precast building – a parking garage.

5 Façade Detailing

An important large assembly for some precast firms is a precast facade. An architectural precast facade is composed of a possibly complex surface partitioned into a set of panels separated by joints between them, with associated regions with different materials, thickness and finishes, with fenestration at some specified layout, with a possibly complex pattern of reveals, bull noses, sills, and surface treatments. The façade must include potentially complex joints with other facades, including non- precast elements.

On the back side, the façade must carry the necessary supporting connections, indents for columns, be adequately reinforced, and carry specified insulation, embeds for electrical and other utilities. Facades are complex assemblies, currently sometimes taking more than a day per panel to draw using AutoCAD.

The PCSC precast application specification addresses most of these requirements. It allows the layout of a façade as a whole, where a façade is one or more planes of the building exterior. The façade layout design consists of parametric positioning of joint lines that might be irregular. Panels are defined by specifying the joints that bound them. Joint details are selected from a predefined library, or one composed for the project. Two figures from the proposed specification are shown in Figure Four (a) and (b). The joint geometries are automatically applied to the panels, creating 3D solids. The joint information also includes bill of material data, allowing these to be accurately derived.

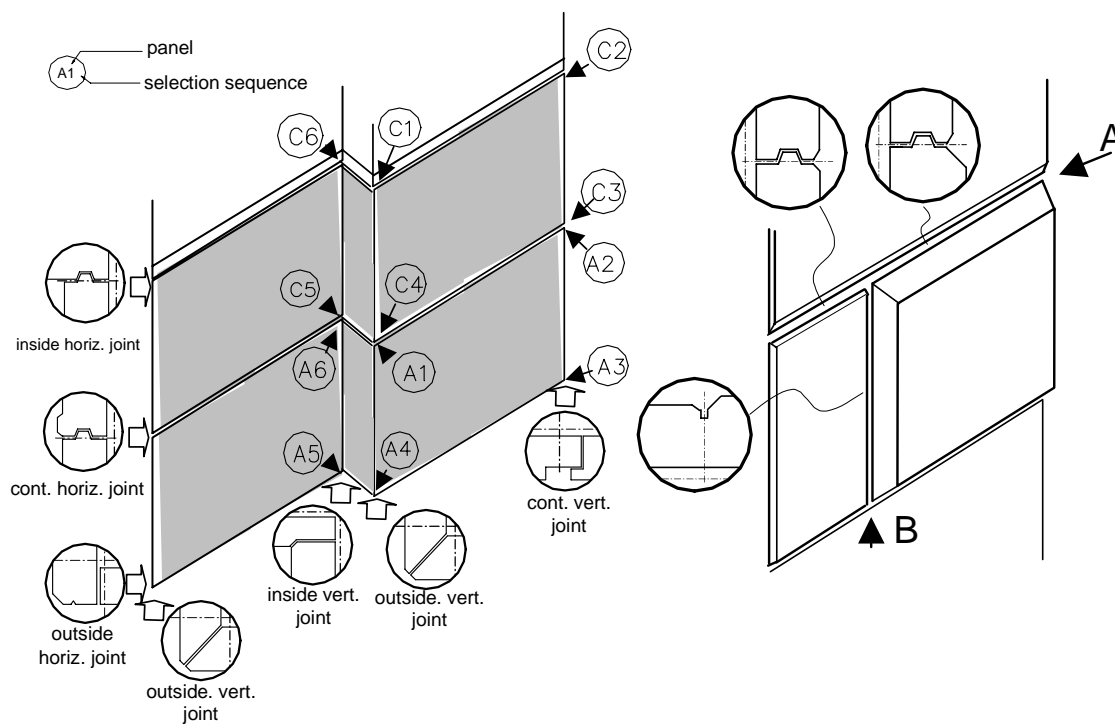

Figure Four (a)

Figure Four (b)

Façade panels are identified by selecting their joint boundaries, in order. Joints may be one or two-sided. Rules have been defined for dealing with two joints that join on a joint line.

Window assemblies are predefined in a company library, then customized as needed for each project. They are embedded as predefined fenestration assemblies, as shown in Figure Five. The sill, arch or other header and jamb conditions are specified, so that they

are automatically aligned with the window. If the window moves, they all do. Like the joints, they modify the 3D model of each precast panel. The precast design components of bills of material for the window assembly are included.

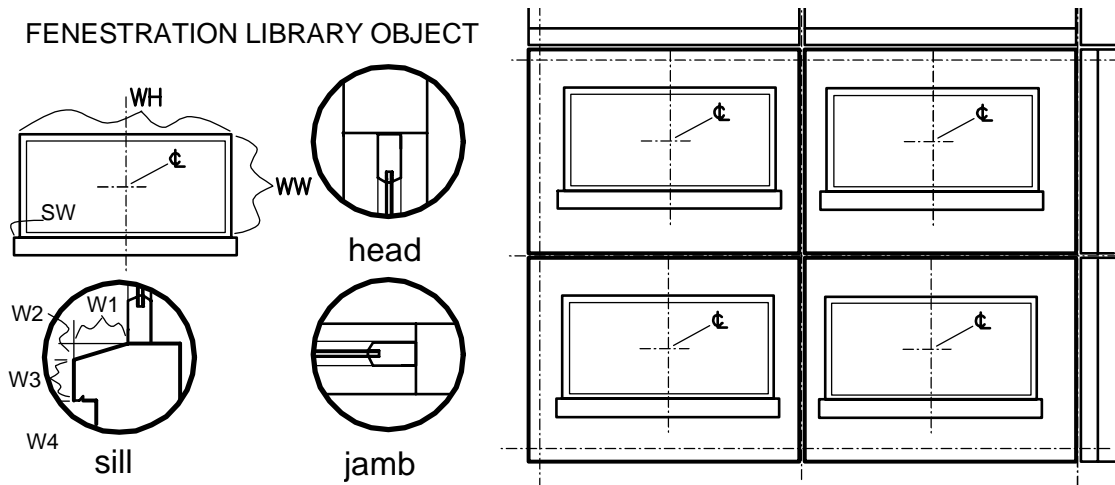

Figure Five – A fenestration library is defined for a project. It includes the panel features that are located with the opening.

Other capabilities provide means to deal with surface treatments, including brick coursework, tiling, reveals, bullnoses and other patterns. Other capabilities include the assignment and detailing of connections, with any subtraction of material required on the inside surface due to structure. See Figure Six. These capabilities are not only layout operations, but rather automatically update themselves as other parts of the design change. It is expected that these capabilities will tremendously facilitate the definition and layout of precast concrete facades, and allow more complex facades to be developed.

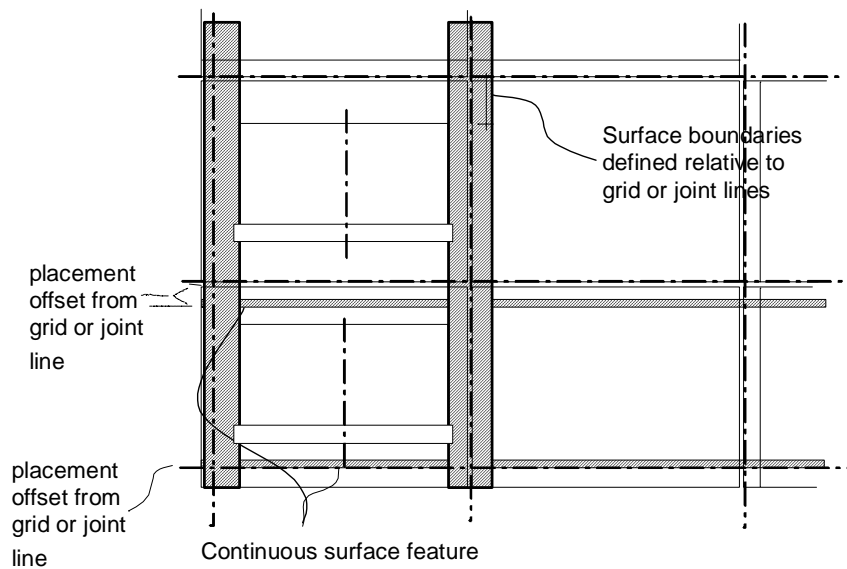

Figure Six – Surface treatment layout is defined parametrically, so that it can be easily adjusted.

From these layouts of a façade assembly, the 3D assembly model is defined, including 3D models of each façade panel. Later, reinforcing, joints for connecting the façade to the structure, insulation panels and conduit, if needed, is added. From the 3D model, piece drawings of each panel are automatically generated, including all of the detail dimensioning, placement of embedded elements and other details needed for fabrication, along with the piece-level bill of materials. If a custom mold is required for the part, a plug-in is envisioned that will support mold definition. Two example facades are shown in Figure Seven.

This façade layout and behavior definition is only one example of over twenty areas of specification now defined in detail for the first production release of the precast software.



Figure Seven: Example architectural façades, models of those to be generated by the Façade Assembly capabilities described (figures courtesy of Concrete Technologies International).

6 Implications for Architecture

This type of technology effectively addresses custom facilities based on standard construction technologies. It appears that more innovative construction technologies, such as incorporated into the buildings of Frank Gehry, are based even more strongly on computer technology. From these examples, it appears that future construction expertise will become more and more embedded in knowledge-based building information systems.

As this technology matures, the roles of designer, draftsmen, and engineers will significantly change, as engineering and drafting are automated. While precast concrete and other building producers are moving strongly into 3D modeling for production purposes, they clearly see the potential of this technology to change the scope of their businesses. Some are planning to use this technology at the early sales stage, allowing potential clients to see and walk through a building, while at the same time getting strong cost estimates and production schedules. A few general contractors have already begun doing the same (MIT, 2001). Alternatively, there is interest by Consortium members to see architects adopt this technology, to speed construction and reduce costs. There is likely to be increasing competition and players competing at the boundaries of traditional services.

Architecture, which at one time aspired to be responsible for the full scope of construction (a la the “master builder”) has in fact traditionally reduced its scope to address ever fewer technical and social aspects of building, leaving these for others. This has been especially true in the schools. However, new construction-level technologies, if strongly adopted by architects, provide the option for architects to regain an active role in downstream construction-level aspects of building. One can also envision a number of parallel systems being developed for specialized architectural practices, where at the design-level detailed knowledge and expertise are important. These might include, for example: libraries and hospitals, airports and other transport facilities.

Note: The work reported here has been undertaken with the support of the Precast Concrete Software Consortium, and has been published with their permission. The authors also acknowledge the Tekla Corporation for their support in this undertaking.

References

- Columbia University (2000) Concrete Materials Research at Columbia University Prof. C. Meyer, Dept. Of Civil Engineering. Mail Code 4709, Columbia University, New York, NY 10027-6699
- Cooke, A. (2000) The Business of Complex Curves, Architecture, December 2000, pp. 54, and 124)

- Crowley, A., and Watson, A., (2000) CIMsteel Integration Standards, Release Two, 5 Volumes, Steel Construction Institute and Leeds University.
- Dunston, Ph.S. and Bernold, L.E. (1993) Intelligent Control for Robotic Rebar Bending, Proceedings of the Tenth International Symposium on Automation and Robotics in Construction, Houston, TX, May 24-26, pp.101-108
- Eastman C. M. and Augenbroe G. (2000), PCI Study: Design Computing Research Report, Georgia Institute of Technology, Atlanta, GA.
- Eastman C. M., Sacks R. and Lee G. (2001), Software Specification for a Precast Concrete Design and Engineering Software Platform, Georgia Institute of Technology, Atlanta, GA, USA.
- Economic Census (2000), Industry Summary, 1997 Economic Census, Document EC97C23-IS, U.S. Dept. of Commerce, Economics and Statistics Division.
- Economic Census (2001), Manufacturing Subject Series for 1997, Doc. # EC97M31S-PS, U.S. Dept. of Commerce, Economics and Statistics Division.
- FCIA (2000), Internal Report, Finnish Concrete Industry Association, Helsinki, Finland.
- IAI, (2003) see http://www.iai-international.org/iai_international/
- Koo, B. and Fischer M. (2000) Feasibility Study of 4D CAD in Commercial Construction Journal of Construction Engineering and Management, ASCE, 126(4), 251-260
- Laiserin, J. organizer, "Autodesk and Bentley debate Building Information Modeling" leading design software executives in face-to-face webcast recorded on April 3, 2003, also Laiserin Newsletter, July1, 2003
- Lee G, Eastman, C. M. and Sacks R. (2003) Eliciting Information for Product Modeling using Process Modeling, Data and Knowledge Engineering (in review)
- MIT (2001) The Beck Group, Bringing DESTINI to Market: Revolutionizing the Industry Case Study: E-Commerce and the Internet in Real Estate and Construction, Construction Engineering and Management, Center for Real Estate, at: www.beckgroup.com/whitepaper/casestudyformit.pdf
- PCI (1999) PCI Design Handbook, Precast/Prestressed Concrete Institute, Chicago.
- PCI (2001), Annual Financial and Cost Data Survey, Fiscal 2000, PCI Precast/Prestressed Concrete Institute, Chicago, 1-69.
- RTT (2001) Yearbook - Economic Outlook - 2000, RTT - Finnish Association of Construction Product Industries, Helsinki, Finland.
- Sacks R., Eastman C. M. and Lee G. (2003a) Process Model Perspectives on Management and Engineering Procedures in the North American Precast/Prestressed Concrete Industry, ASCE Journal of Construction Engineering and Management, (in press).

Sacks, R., Eastman, C.M., and Lee, G., (2003b) Process Improvements in Precast Concrete Construction Using Top-Down Parametric 3-D Computer-Modeling, *Journal of the Precast/Prestressed Concrete Institute*, Vol. 48 No. 3 pp. 46-55.

Sacks, R., C. M. Eastman, and G. Lee. (2003c). Parametric 3D modeling in building construction with examples from precast concrete. *Automation in Construction*, (in press).